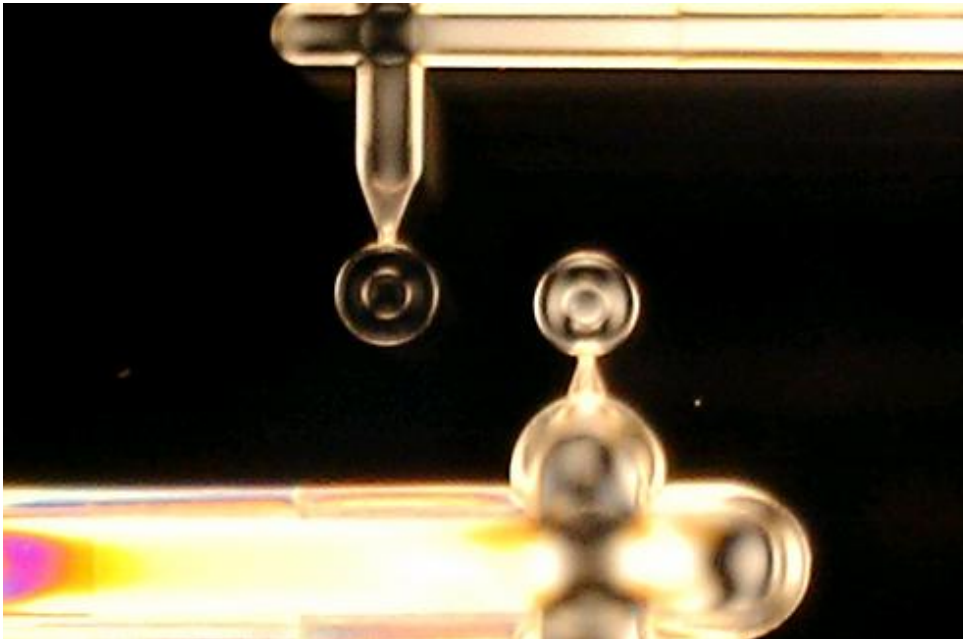


***TOPAS®5013 Series***

***Proposal for Reduction in Optical Lens Cost by  
Using high-flowability COC***



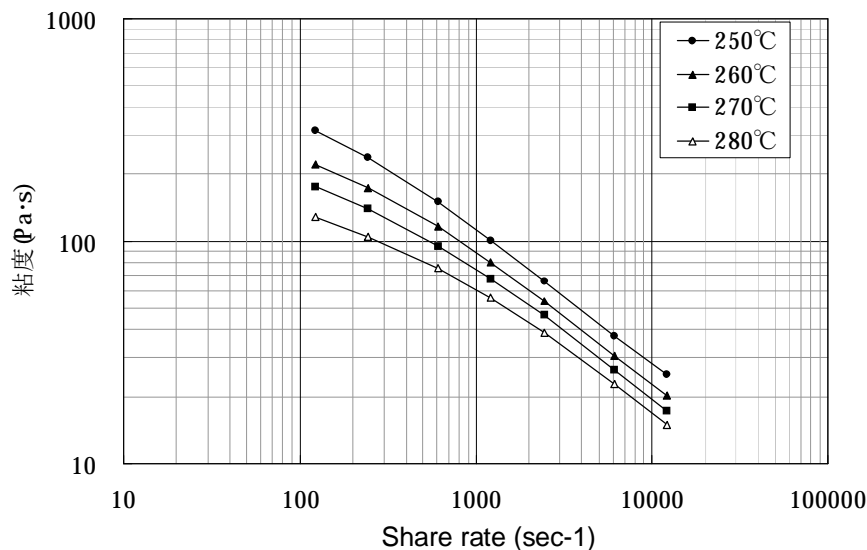
***TOPAS® Cyclic Olefin Copolymer (COC)  
Your Clear Advantage in Optics***

*Polyplastics Co. LTD.*  
TOPAS Business Development Unit  
27-Feb 2007

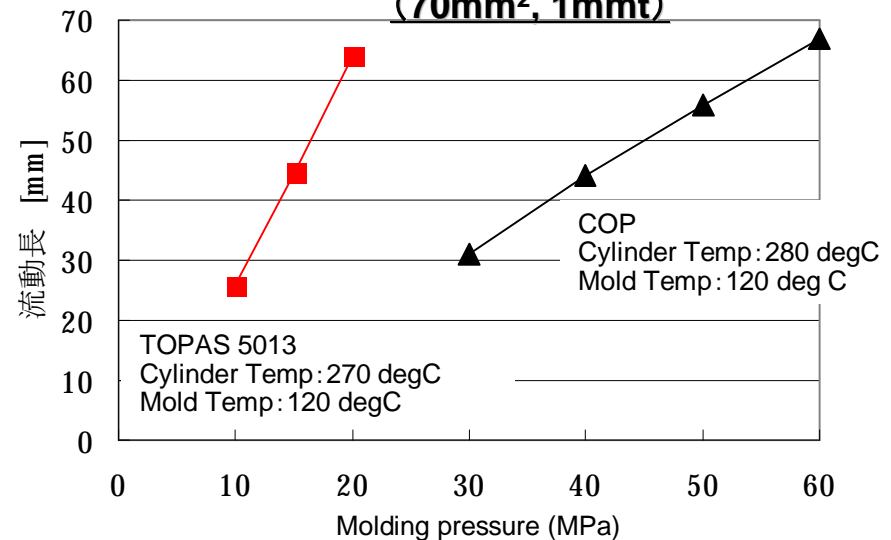
## q Since TOPAS®5013 series has extremely high flowability...

- n The overall size of sprue runner can be greatly reduced.
  - à For lenses with a higher sprue runner ratio, losses can be halved.
  - à It provides a significant advantage to optical parts for which no recycled material can be used.
- n Superior productivity (replicability) can be provided.
  - à Shape precision can be improved and mold work start-up can be shortened.
- n Injection molding machine can be downsized.
  - à A one-size smaller molding machine can be used with an increased number of molded product per shot.
- n The molding cycle can be shortened.
  - à The small runner size can shorten the cooling time and molding cycle time.

**Graph-1: Viscosity of TOPAS ®5013**



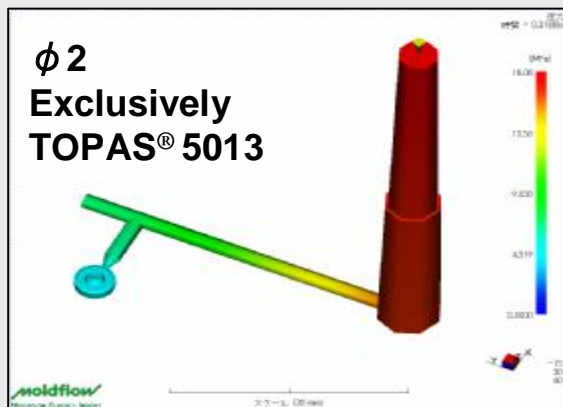
**Graph-2: Comparison TOPAS5013 vs COP (70mm<sup>2</sup>, 1mmt)**



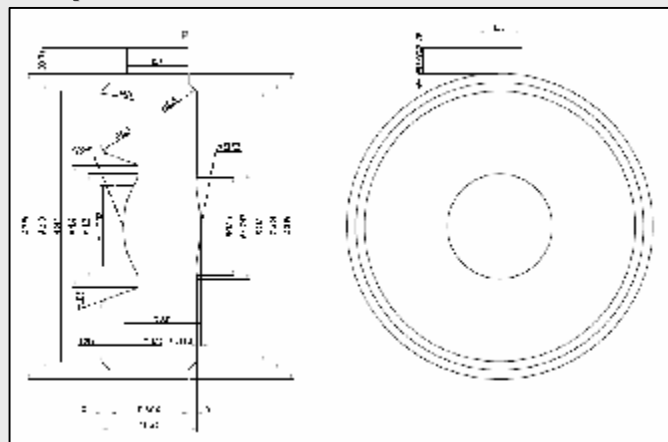
## q Sample examination on molded lens

- à Precision of shape transcription was evaluated by 4 cavities lens mold (Lens dia.  $\phi$  3.5)
  - ・Fluidity was analyzed using Moldflow™ to examine the runner diameter; the operation was started in mode of  $\phi$  2 /  $\phi$  5 switching. (4 cavity  $\times$  2 pattern with common sprues)

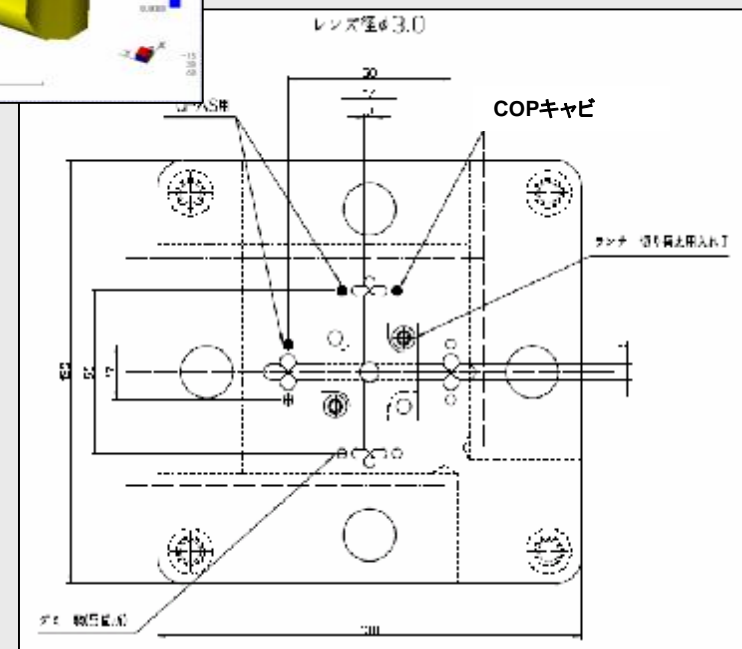
**Fig-1 Result of analysis**



**Fig-2  $\phi$  3.5 Shape of aspherical lens**

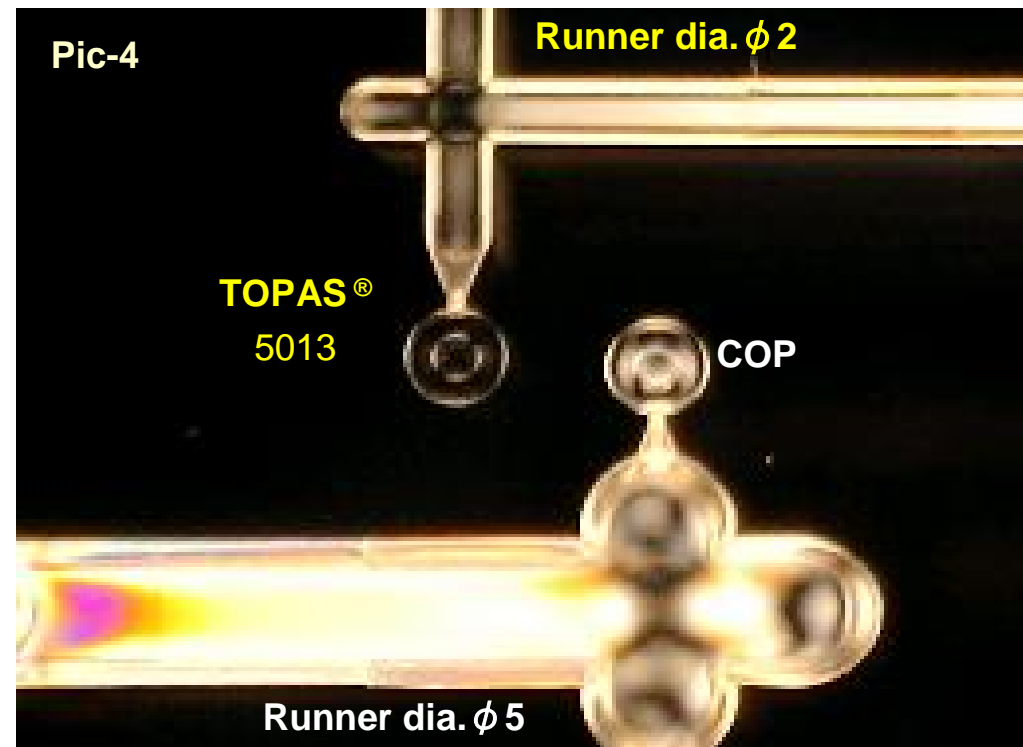
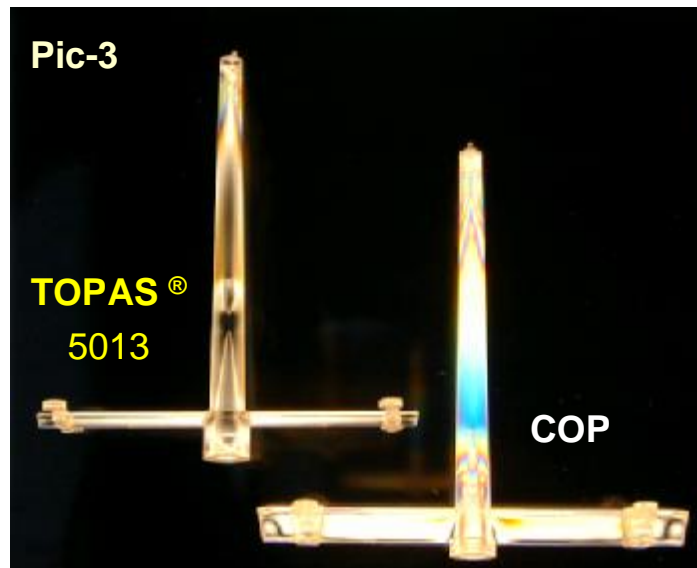


**Fig-3 Cavity layout**



## q Sample result of examination on a molded lens

- n The overall size of sprue runner was successfully reduced by 46% as a result of the combination of a  $\phi 2$  runner with TOPAS<sup>®</sup> 5013. (*Runner weight 2.55g to 1.37g*)
- à The filling pressure reduced 20% despite the small-diameter runner.
- à Lens with low level birefringence can be molded.



$\Phi 3.5$  molded lens

## q Dimensional precision of molded lens

- à Even with the  $\phi 2$  runner, **TOPAS® 5013** was confirmed as relating excellent dimensional precision.

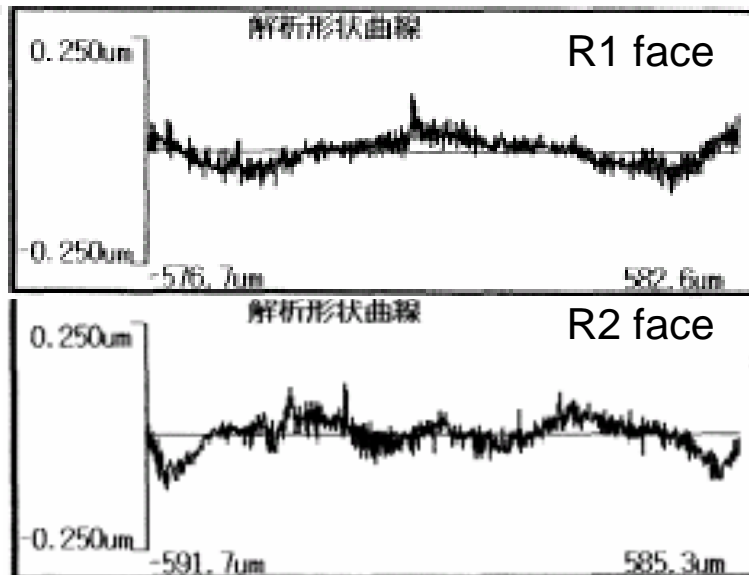
Molding data (actually measured value)

**TOPAS® 5013** + exclusive design  $\phi 2$  runner

1 shot weight: 1.37g

Filling pressure: 67MPa

Fig-4

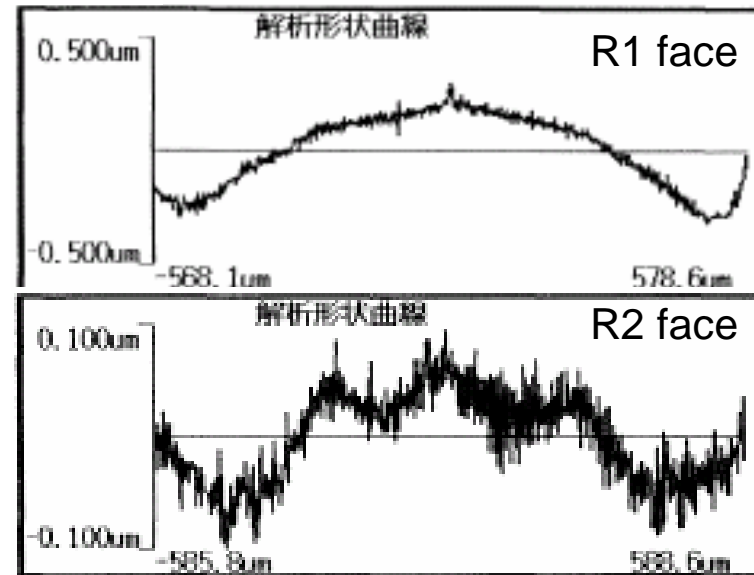


**COP** + conventional design  $\phi 5$  runner

1 shot weight: 2.55g

Filling pressure: 85MPa

Fig-5

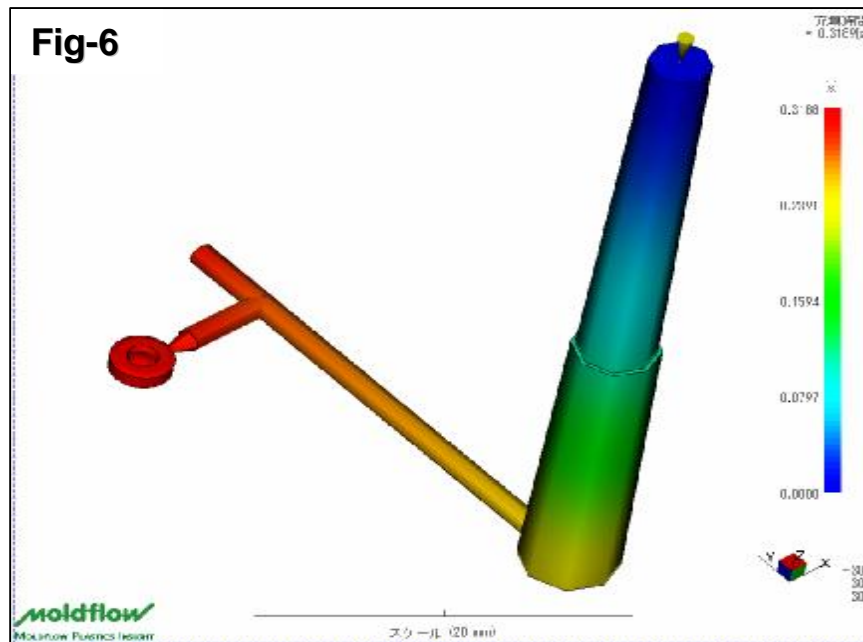


Sample result for lens surface precision measurement

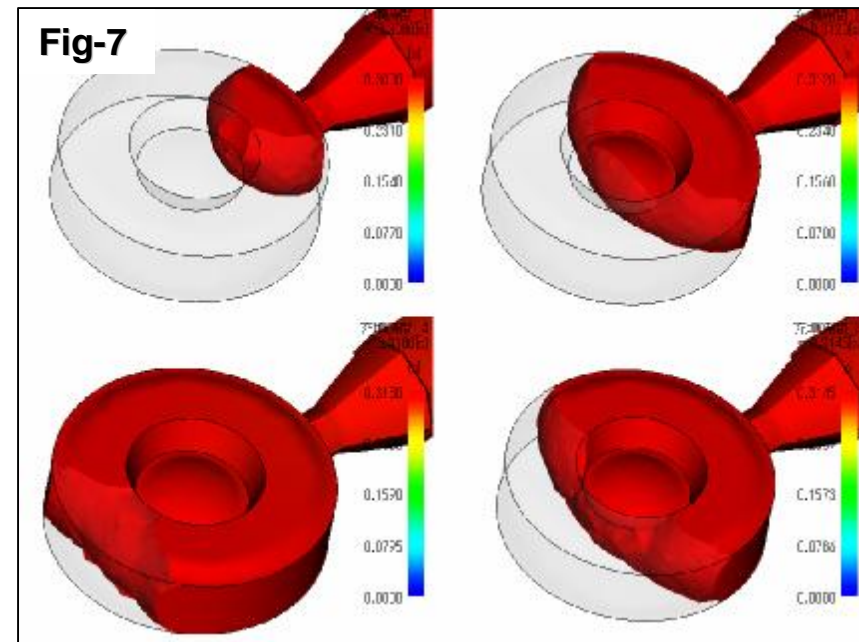
## q Design of TOPAS<sup>®</sup> 5013 Mold

à We will propose the runner size reduction by analyzing fluidity using Moldflow<sup>™</sup>

Ex) 3-D analysis model of lens



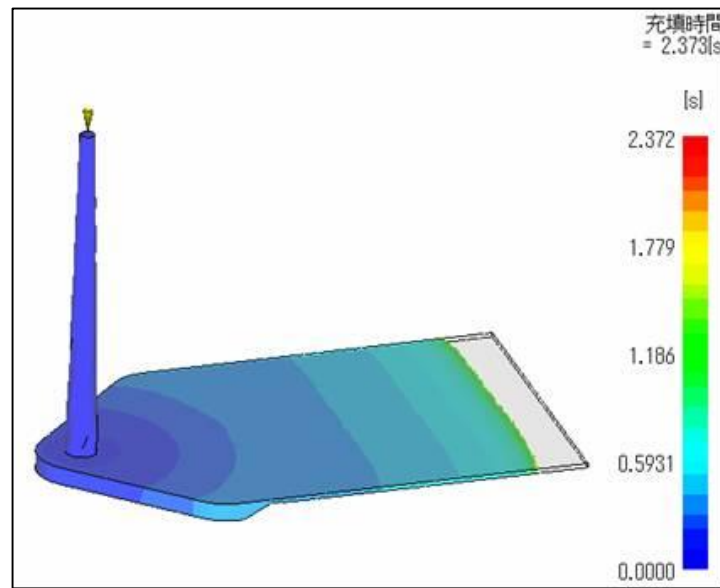
Ex) cavity-filling pattern



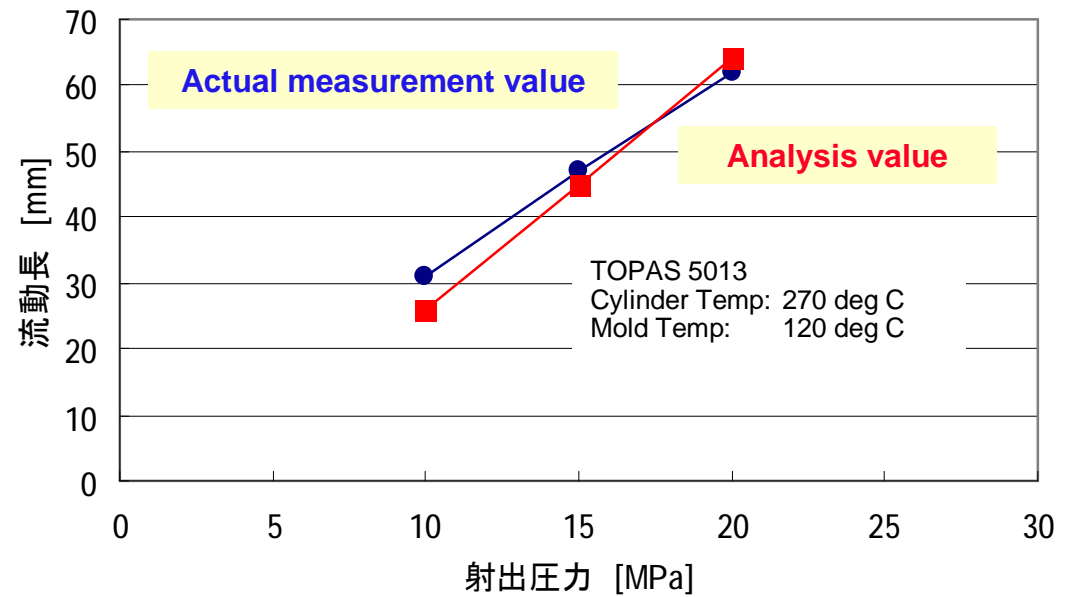
# Reference

Result of fluidity analysis (70mm<sup>2</sup>, 1mmt)

Fig-8



Graph-3 Result of examination of flow length



n With reference to the flow length, it has been confirmed that superior accuracy can be provided.

## Notes

- q Property values shown in this information include those actually measured at our company or typical ones in accordance with various standards and testing methods.
- q Data in this technical information neither guarantees quality nor the results evaluated by third parties

[Contact:]

- I Polyplastics Co., Ltd.  
TOPAS® Business Development Unit  
TEL +81-3-6711-8615  
FAX +81-3-6711-8617  
E-mail: topas.info @ polyplastics.com