

Cyclic Olefin Copolymer – A High Performance Modifier for Conventional Polyolefins

**SPE Polyolefins 2007 Conference
February 25 – 28, 2007**

TOPAS® Cyclic Olefin Copolymer (COC)

A New Addition to the Ethylene Copolymer Family



- **Polyolefin Resin**
- **Amorphous**
- **Clear and Colorless**
- **High Purity**
- **High Moisture Barrier**
- **Good Chemical Resistance**
- **Easy to Process**

COC - Production Plant



- Production plant on stream since Oct 2000
- 30 000 tons / year production capacity
- Backward integrated in Norbornene
- Largest Cyclic Olefin Copolymer (COC) plant in the world

Large scale production COC enables TOPAS Advanced Polymers Inc. to offer competitive pricing



Glass Transition Temperature as a Function of Norbornene Content

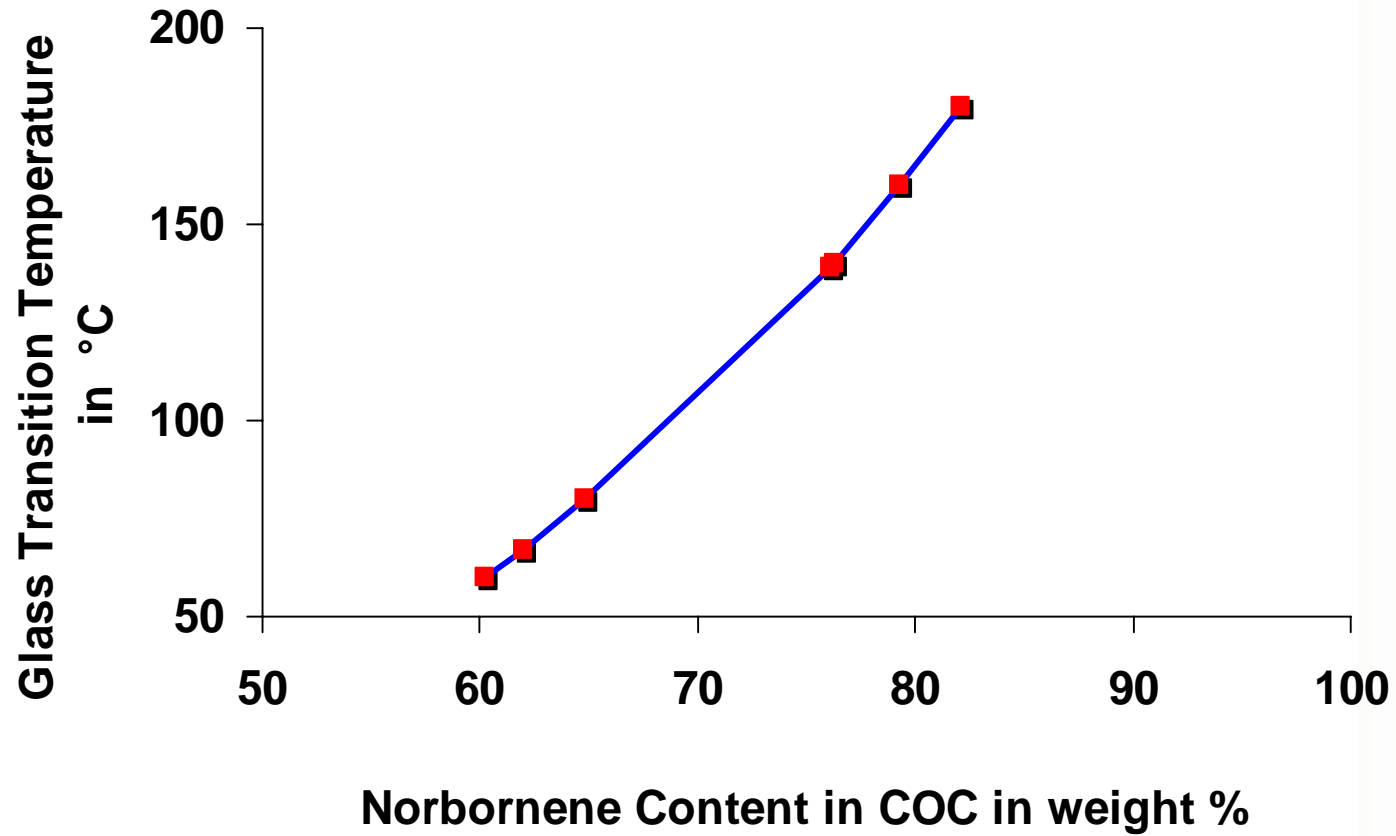

COC - Basic Properties

Glass transition temperatures, °C(°F)

70 - 180 (154 – 356)

Modulus of elasticity, N/mm² (kpsi)

2600 – 3200 (380 – 460)

Tensile strength, N/mm² (kpsi)

66 (10)

Density, g/cm³

1.02

Water uptake, %

< 0.01

WVTR, g × mm/m² (mil/100 in²) × day

0.02 - 0.04 (0.05 – 0.10)

- Glass Clear, Transparent
- Sterilizable via Steam, EtO, gamma, beta (E-beam)
- Resistant to Alcohols, Acids, Bases, Polar Solvents
- High Purity, Low Extractables
- Low Water Transmission Rate (WVTR)
- Biocompatible
- Halogen-free

TOPAS® COC – Regulatory Status

- FDA Regulation 21 CFR 177.1520 (3.9)
- TOPAS® COC FDA Food Contact Notification (FCN #405) covers all applications, including films and bottles, for all food types under all conditions of use. (See <http://vm.cfsan.fda.gov/~dms/opa-fcn.html>)
- FDA Drug Master File, DMF# 12132, established.
- FDA Device Master File, MAF# 1043, established.
- The monomers are listed in EU Directive 2002/72/EG
 - Norbornene has a SML = 0.05 mg/kg.

**TOPAS® COC meets all major regulatory requirements
for food contact and medical use**

COC - Film & Packaging Core Segments



**COC enhances a broad range
of film and packaging applications**

Typical Film Structures (blends)

COC / Polyethylene Blend Films

- LDPE, LLDPE, Plastomer, EVA
 - Semi-compatible blends
 - Increasing compatibility
HDPE - LDPE - LLDPE - Plastomer
- Depending on...
 - crystallinity (density, refractive index)
 - side chains, viscosity
- Typical blend mixes
 - 5 - 30% PE in COC
 - 5 - 30% COC in PE

COC - Enhancement in Value

Customized Performance

■ Barrier

- WVTR = extended shelf life
- Special barrier (e.g. acetic acid, alcohol, aroma, flavor, acids, bases, peroxide; moderate gas barrier)

■ Mechanical Properties

- Added stiffness = downgauging of softer polymers
- Improved thermoforming
- Higher temperature resistance
- Controlled tear
- Better puncture resistance
- Lower COF

■ Seal Properties

- Improved seal strength, hot tack and temperature window

COC - Barrier Properties

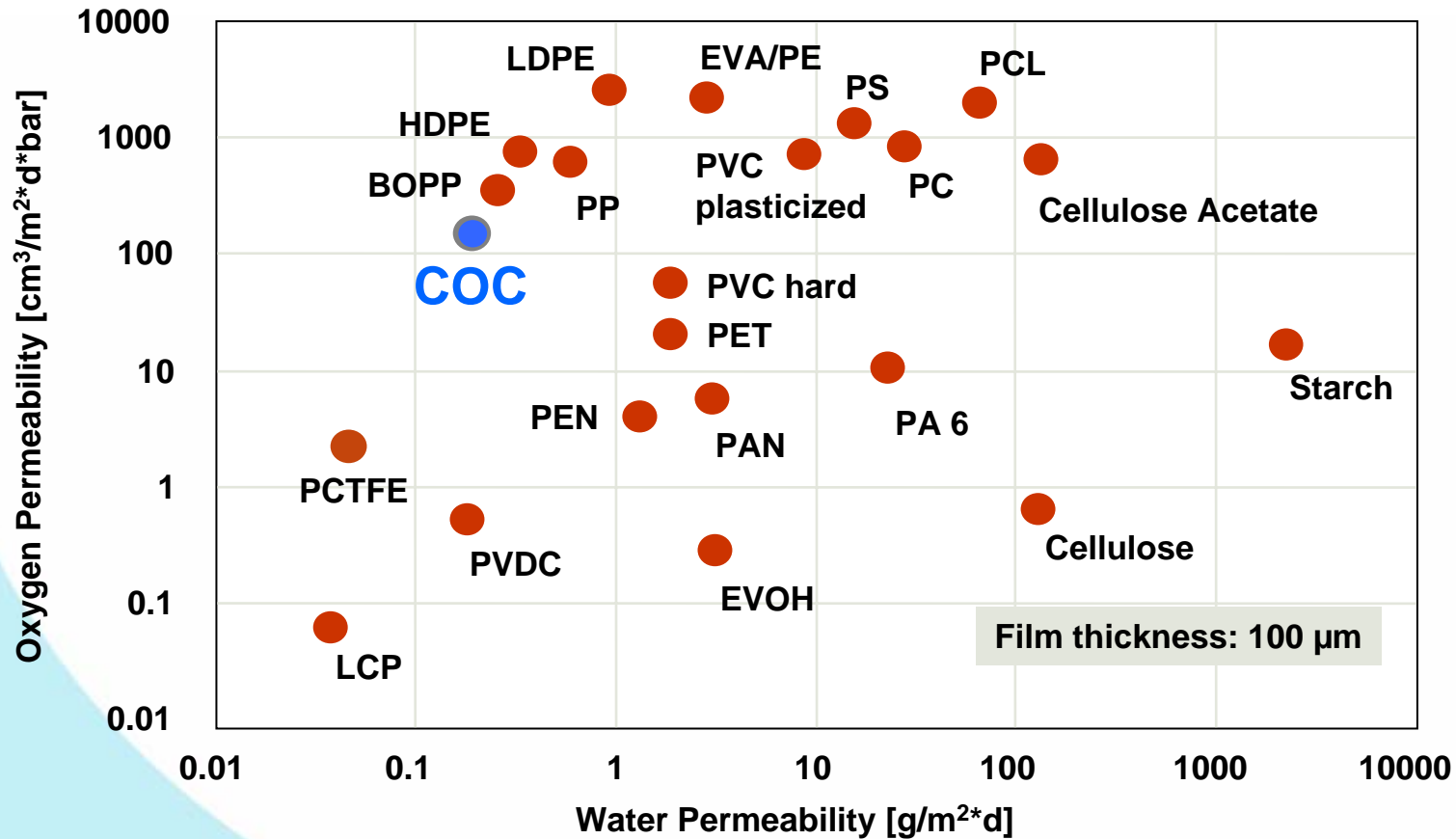

COC can extend the shelf life of products due to its very high moisture barrier

Barrier Properties in PE/COC Blends

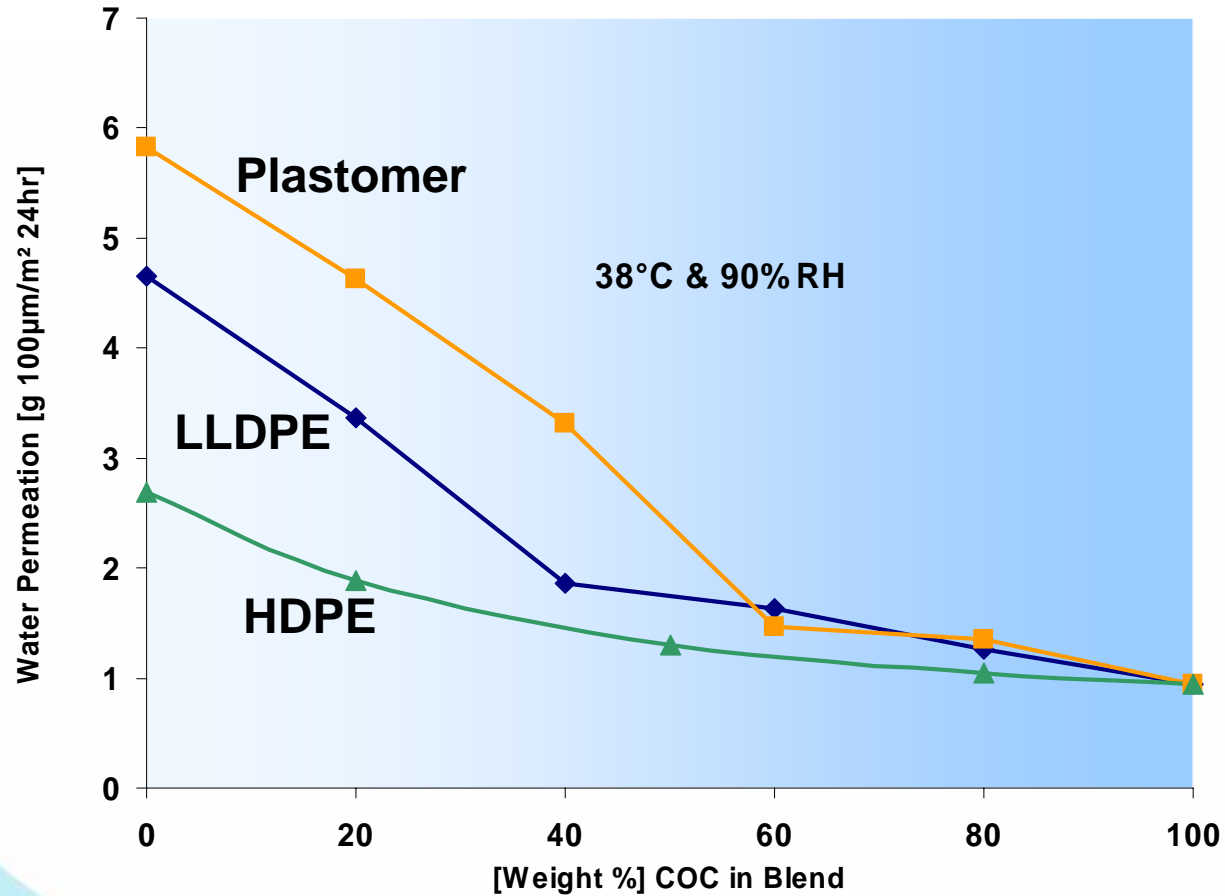

Materials: LLDPE Dow 2035, Plastomer ExxonMobil 3125, HDPE ExxonMobil HDZ222, 78C Tg COC

Aroma/Odor Barrier

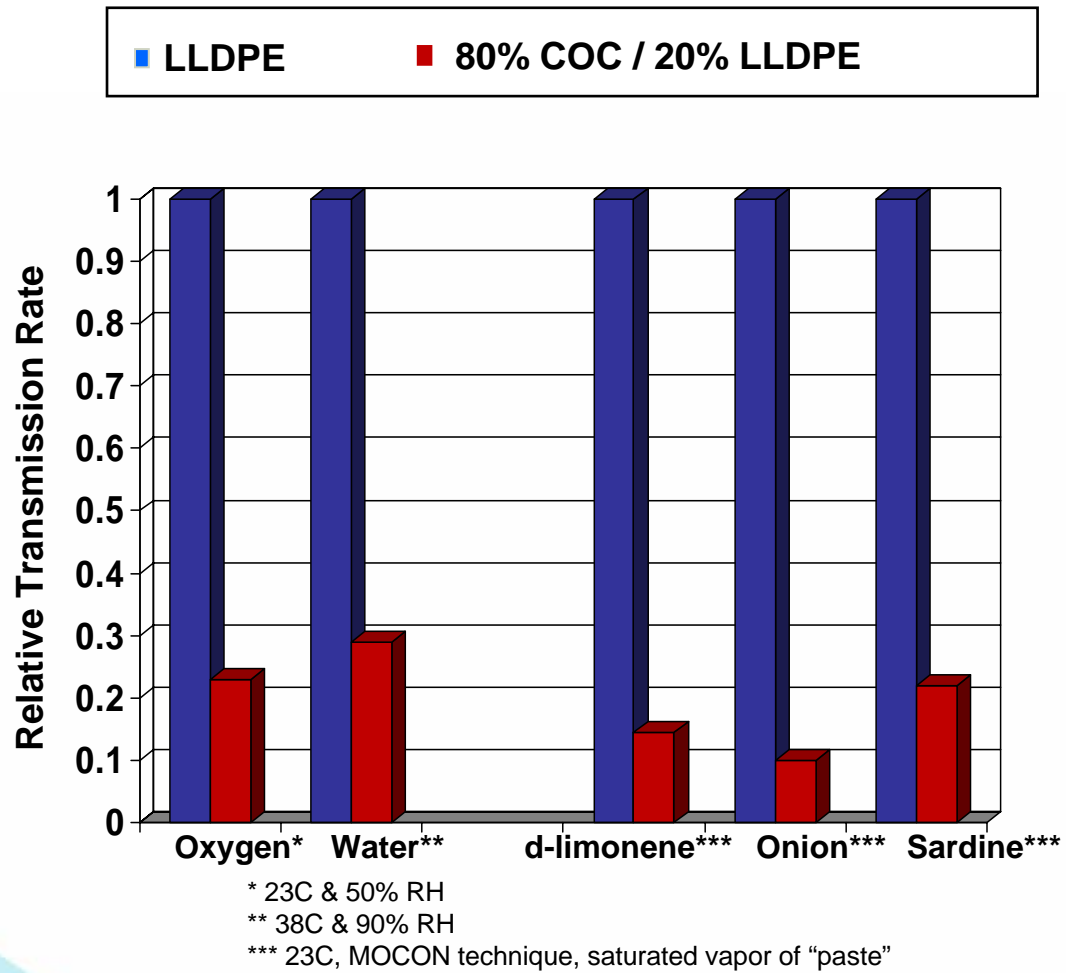

COC - Laminates / Pouches for Food and Non-food Applications

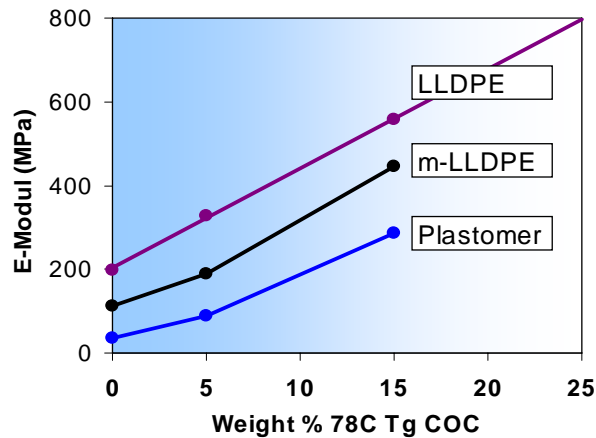

Description:

Multi-layer pouches with PE/COC sealant layer

Value Proposition:

Improved stiffness
Potential for downgauging
Excellent clarity & gloss
Controlled easy tear properties

Grade:

78°C Tg COC

Customer:

Not disclosed

Modulus as a Function of Temperature

2.7 mil Three-Layer Blown Film (COC + PE Blend / PE / COC + PE Blend)

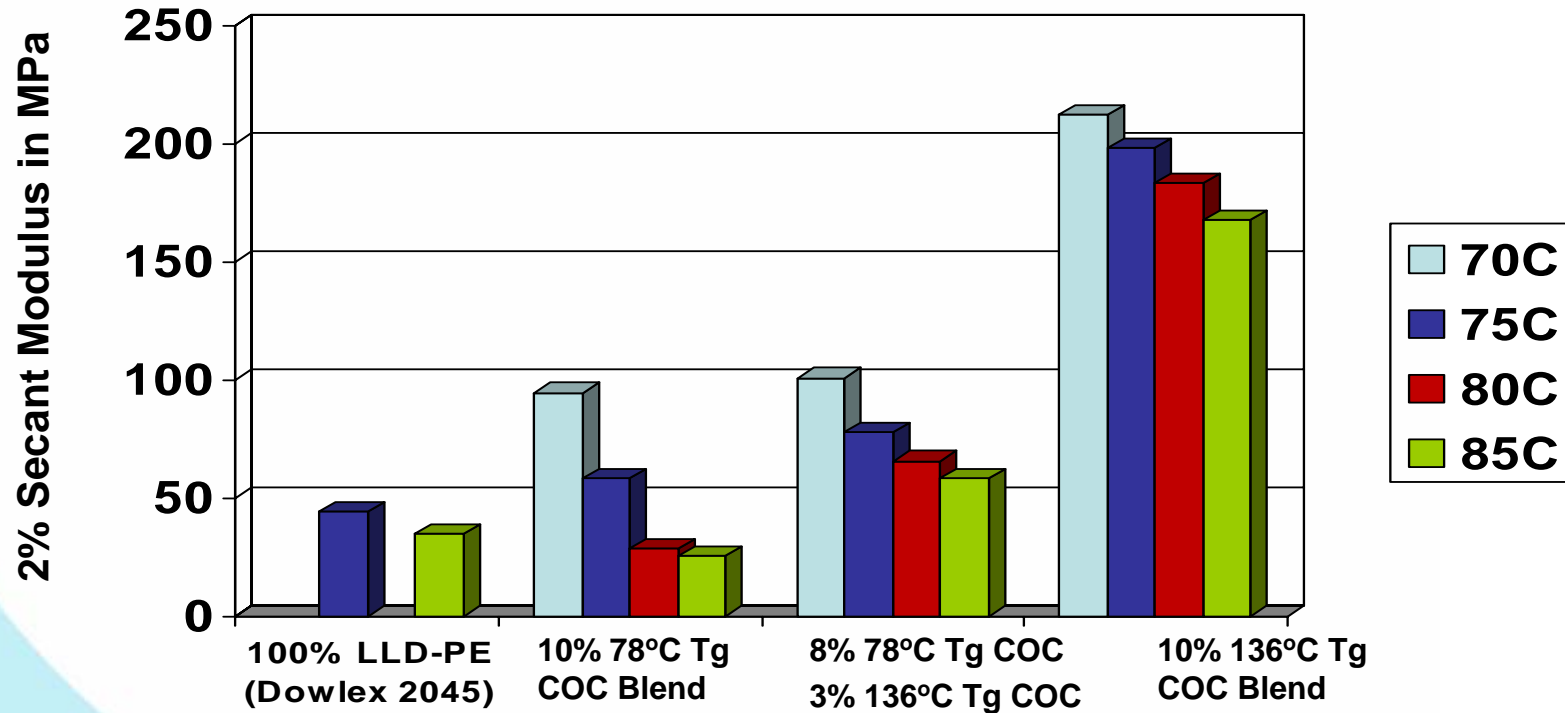

136°C Tg grade dramatically increases hot-fill temperature modulus of PE

COC/HDPE Blends High Temperature Modulus Retention

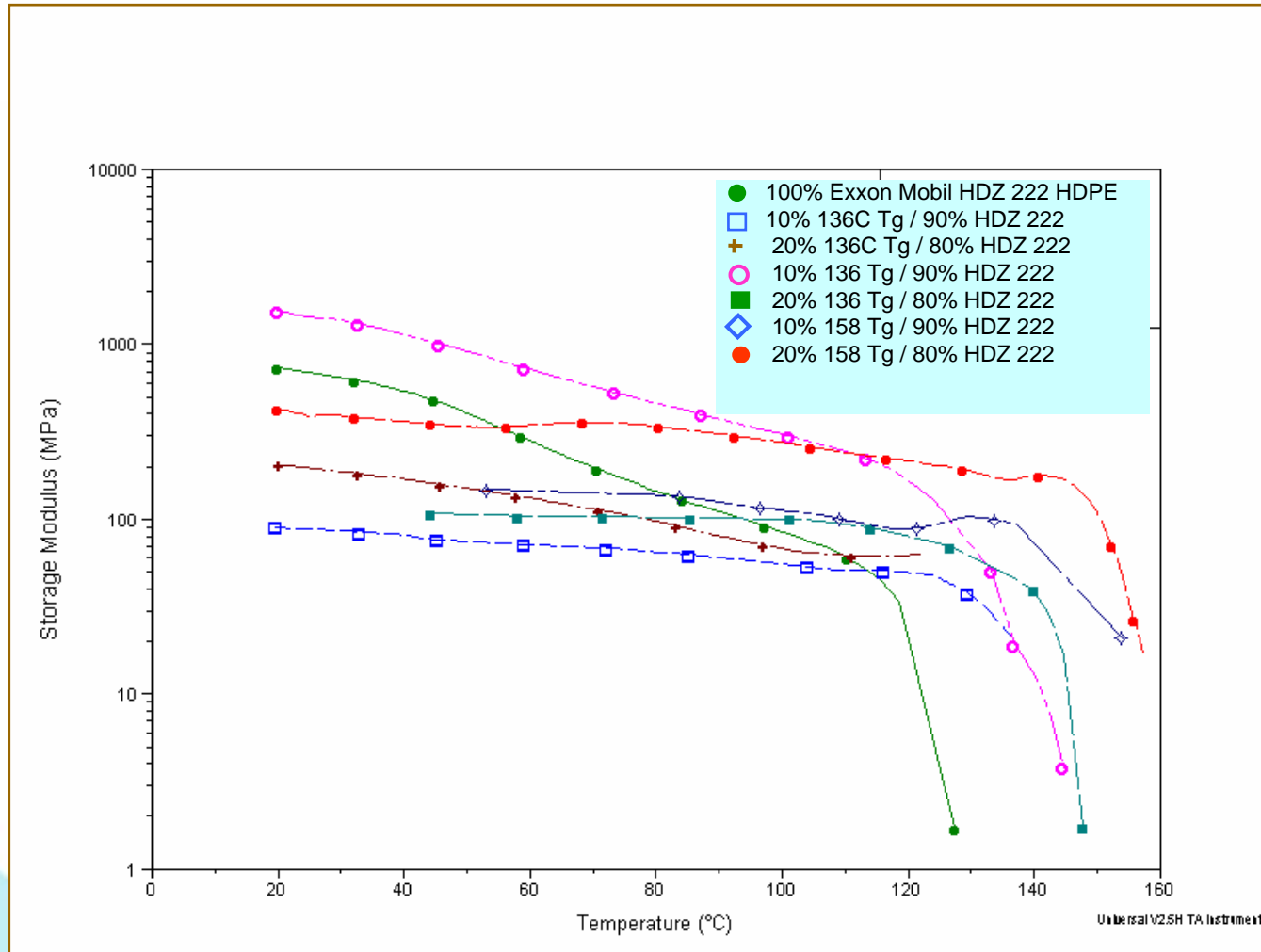

High Tg COC reduces the rate of modulus reduction with temperature increase and increases the heat deflection temperature (HDT)

COC - Steam Sterilizable Blister



138C Tg COC + LLDPE
Stretching Ratio 2 at 150 °C

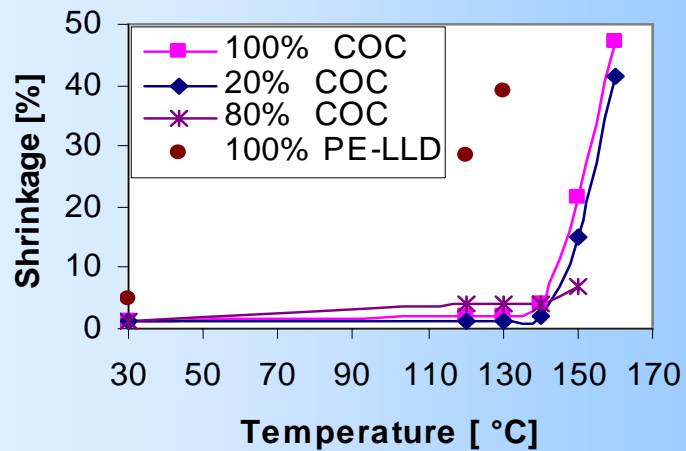

Description:

Post-sterilizable forming film
Monolayer film (COC-rich blend)

Value Proposition:

No shrinkage and distortion of blister film during steam sterilization (121°C/ 20min)
High moisture barrier
Excellent forming and die cutting behavior
Polyolefin solution

Grade:

136°C Tg COC

Converter:

Advanced Technology

Thermoformed 4.7-mil monolayer COC vs. 6-mil Polyolefin coex

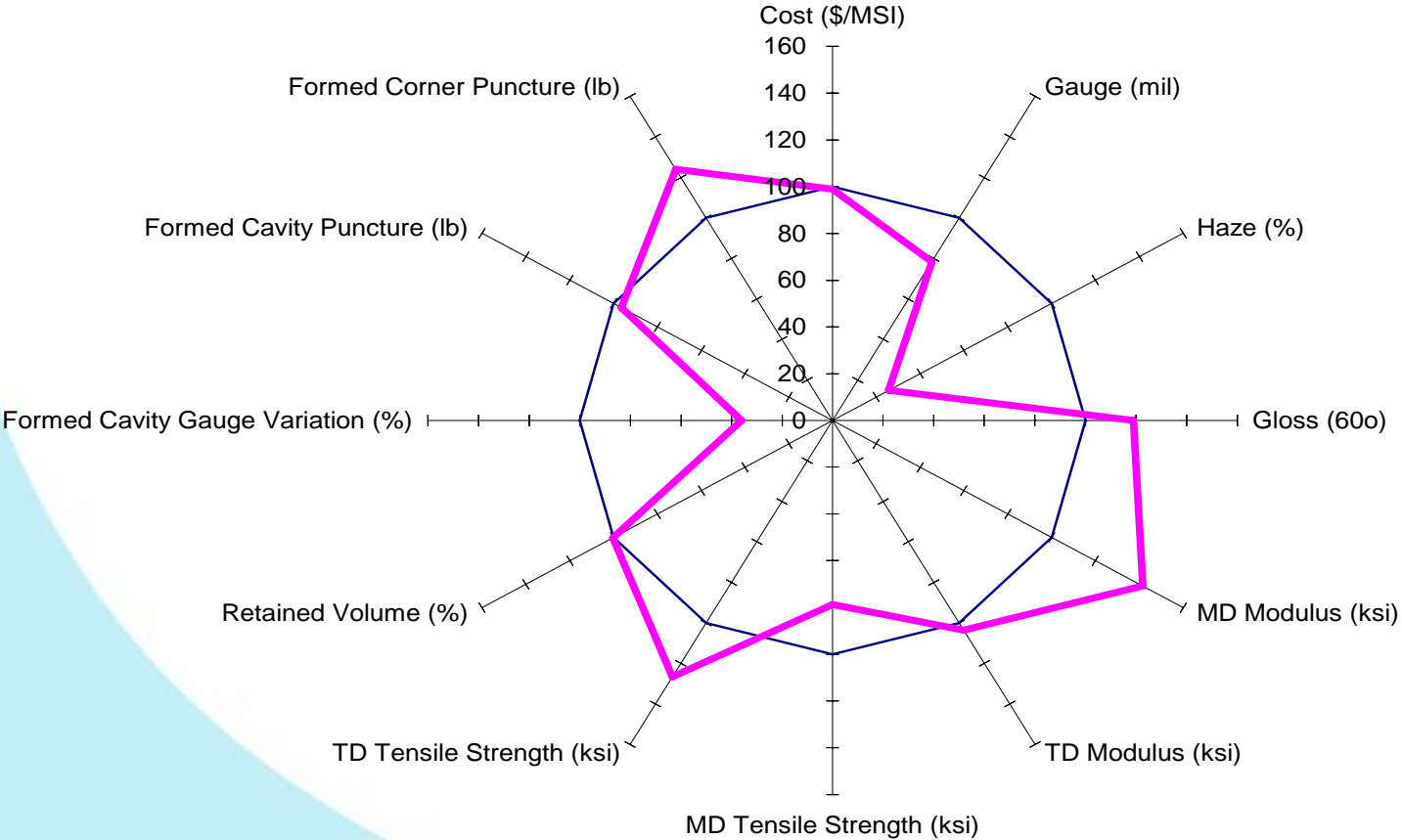

COC - Bottom web for food packaging



Description:

Formable bottom web of meat packaging, blend with LLDPE in multilayer film with EVOH as an oxygen barrier

Value Proposition:

Excellent thermoformability
Improved toughness
Improved puncture resistance
Potential for down-gauging

COC Grades:

68°C Tg and 78°C Tg

Customer:

Not disclosed

COC - Medical Device Packaging

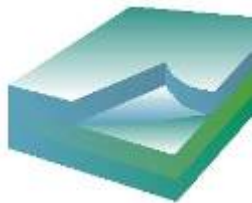

PE
PE/COC blend
PE

Description:

Forming web for medical device packaging with PE/COC blends

Value Proposition:

Good forming properties
Excellent dimensional stability
Excellent stiffness
Cost-effective solution

COC Grades:

68°C Tg and 78°C Tg

Customer:

Not disclosed

COC - Zipper/Closure System for Bags



Description:

Zipper application (Pactiv Hefty® Slide-Rite®) for sliced ham, turkey and roast beef

Value Proposition:

Shrinkage control (no camber)
Easy open / close
Mechanical strength / stiffness
Moisture barrier



COC Grades:

68°C Tg and 136°C Tg

Customer:

Pactiv, US
Others

COC - COF Modification

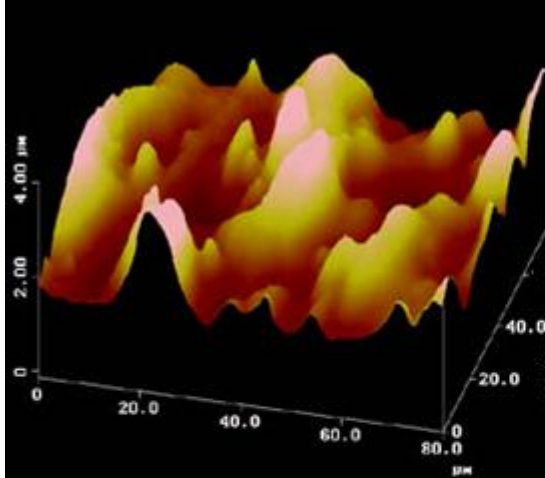

Description:

COC as polyolefin additive for low COF

Value Proposition:

Non-migratory

Non-contaminating

Blocking reduced

COCGrade:

78°C Tg COC

Customer:

Not disclosed

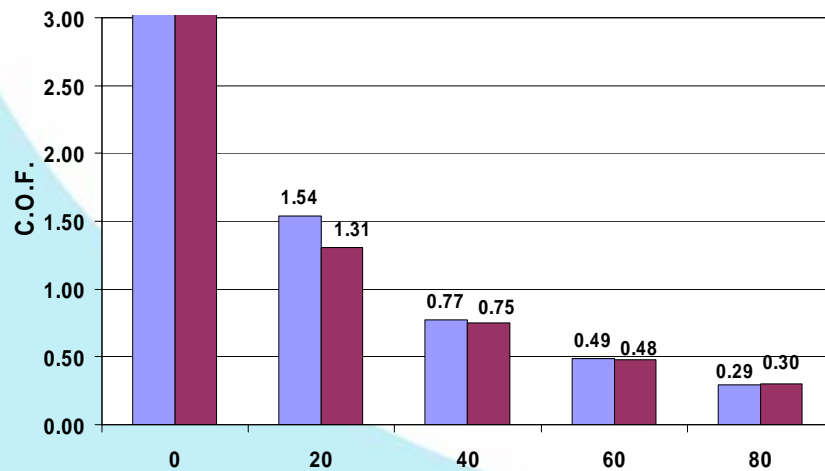

COC Addition Improves Seal Characteristics

- Seal Strength is typically maintained or improved at low Tg COC addition levels up to 15% in LDPE, LLDPE and elastomers.
- Hot-Tack strength is increased up to 100% with the addition of 15% low Tg COC in LDPE, LLDPE, and elastomers.
- Seal Initiation Temperature (SIT) can increase by 5 – 10°C with low Tg COC levels of 15% depending on the base polyolefin.
- Blends using high Tg COCs typically reduce sealability and can be utilized to reduce seal bar sticking in non-seal film surfaces.

COC - Cast Film Extrusion

Start-up Conditions

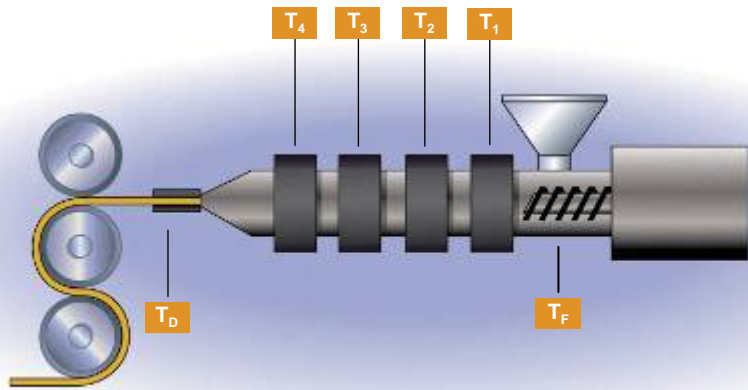

- COC can be extruded on a variety of commercial cast film lines.
- Recommended screw design:
 - Barrier flight screw with shear/mixing section
 - Screw diameter of 65 mm (2.5 in.) or greater
 - L/D ratio of 24:1 and low compression ratio (2:1)
- Head pressure of > 140 bar (~ 2000 psi) is preferred. Use fine screen packs to generate head pressure if needed.
- Run extruder at high screw speed (> 50% nominal).

T_g [°C]	Melt Index [cc/10 min]		Die T_D [°C]	Front T_4 [°C]	Center T_3 & T_2 [°C]	Rear T_1 [°C]	Feed T_f [°C]
	190 °C	230 °C					
68	1.5	8	230 - 240	230 - 240	230 - 240	210 - 220	60 - 70
80	2.0	12	230 - 240	230 - 240	230 - 240	210 - 220	60 - 70
136	< .1	11	230 - 240	250 - 260	250 - 260	220 - 230	60 - 70
140	< .1	2.3	230 - 240	250 - 260	250 - 260	230 - 240	60 - 70
160	< .1	0.4	250 - 260	270 - 280	270 - 280	250 - 260	60 - 70

Summary

- COC has good compatibility with most polyolefins.
- Addition of relatively low levels of COC can dramatically increase the modulus of polyolefins and the modulus enhancement is maintained up to the T_g of the COC.
- COC addition can be used to improve the barrier of polyolefins or to “fine tune” a target transmission.
- COC improves seal characteristics of many polyolefins.
- COC can function as a non-migratory COF reducer.